

ROLLING JACK PLATFORM (OPTIONAL) - ILLUSTRATION #12

ASSEMBLY INSTRUCTIONS:

- 1.) ATTACH BRAKE ASS'Y. TO PLATFORM WITH FOUR (4) 1/4-20 x 1/2" HEX BOLTS, LOCK WASHERS & FLAT WASHERS.
  - 2.) THREAD TWO (2) JAM NUTS ONTO BRAKE ROD. THREAD THE ROD INTO THE BRAKE ASSEMBLY.
  - 3.) ATTACH FOUR (4) NYLON SLIDERS, ONE (1) TO EACH CORNER OF PLATFORM, WITH 1/4-20 x 1/2" HEX BOLT AND FLAT WASHER.
  - 4.) ATTACH FOUR (4) CAM ROLLERS TO PLATFORM (ROLLERS MUST BE ON THE OUTSIDE OF END PLATE) WITH WASHER AND 7/8" HEX NUT.
- \* 5.) AFTER PLACING PLATFORM ON LIFT RAILS, ADJUST THE BRAKE ROD SO IT WILL HOLD THE PLATFORM IN PLACE WHEN APPLIED.

TOOLS NEEDED:

- 7/16" WRENCH
- CRESCENT WRENCH
- STR. SLOT SCREWDRIVER

- \* **NOTE:** PLATFORM MUST BE INSTALLED ON LIFT WHILE ONE OF THE RAMPS IS STILL LOOSE. (SEE ILLUSTRATION #12A)

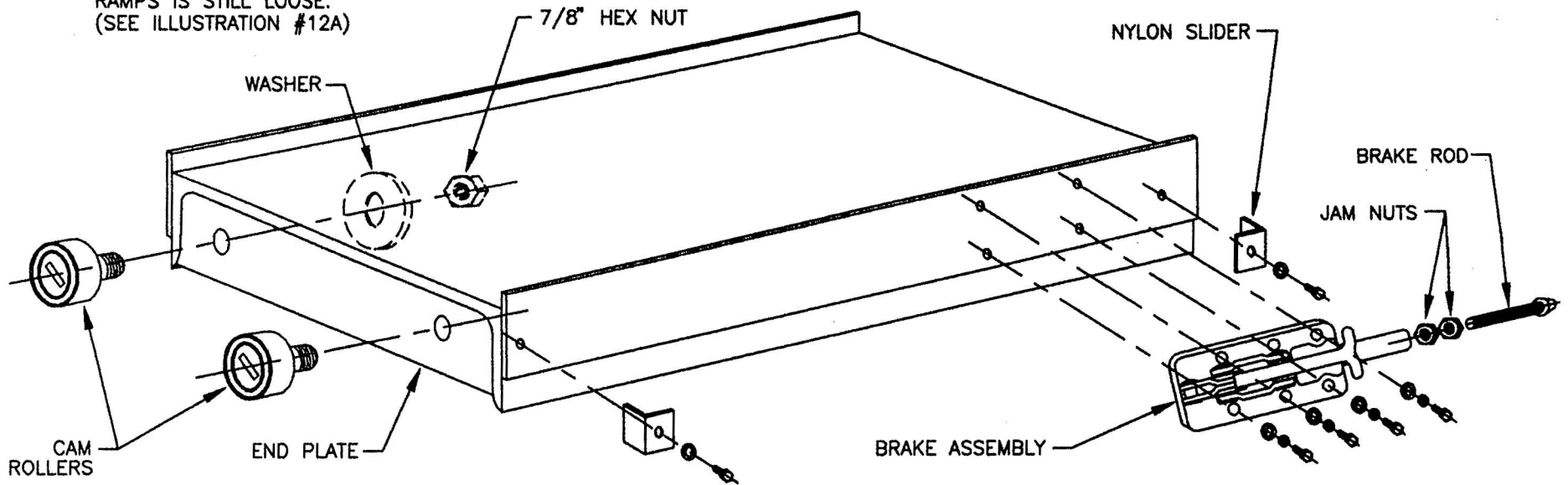

ROLLING JACK PLATFORM ASSEMBLY DIAGRAM (OPTIONAL) - ILLUSTRATION #12B